

X Kilitli  $\geq 5mm$

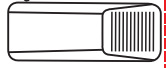

O Kilitli  $\leq 2mm$

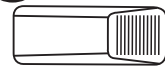

  
**DİKKAT**

En üst 3 basamağı kullanmayın veya üzerinde durmayın.  
Dengenizi kaybederek düşme riski oluşabilir.  
Talimatlara uyulmaması ciddi yaralanma veya ölüme neden olabilir.

  
**DİKKAT**

**DİKKAT**

**KULLANMADAN ÖNCE  
DESTEK ÇUBUĞUNU  
MERDİVEN AYAKLARINA  
MONTE EDİN**

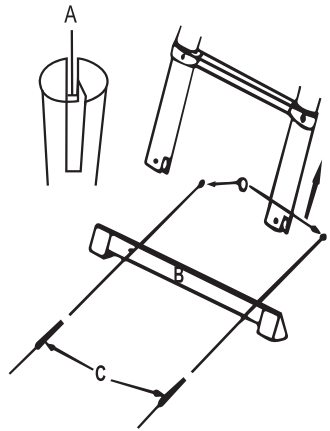

**PARÇA LİSTESİ**

[A] EZİLME ÖNLEYİCİ ÇUBUK  
[B] DESTEK ÇUBUĞU  
[C] 2 ADET CİVATA  
[D] 2 ADET SOMUN

**DESTEK ÇUBUĞU  
MONTAJ TALIMATI**

(A) EZİLME ÖNLEYİCİ ÇUBUĞU  
BASTIRARAK ÇIKARIN

(B) DESTEK ÇUBUĞUNU MERDİVEN  
AYAKLARINA YERLEŞTİRİN

(C) CİVATALARI BAĞLANTI DELİKLERİNDEN  
GECİREREK TAKIN

(D) KİLİT SOMUNLARINI TAKIP  
SIKIÇA SABİTLEYİN

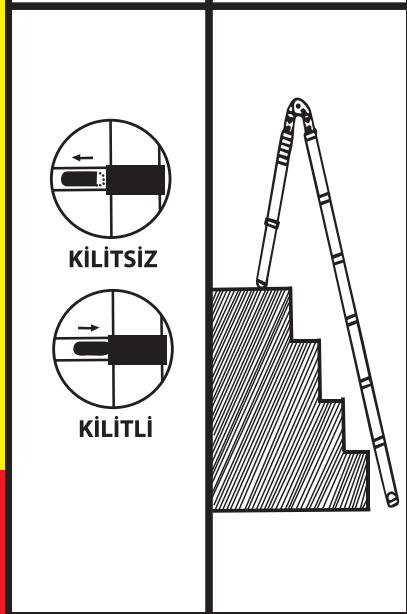
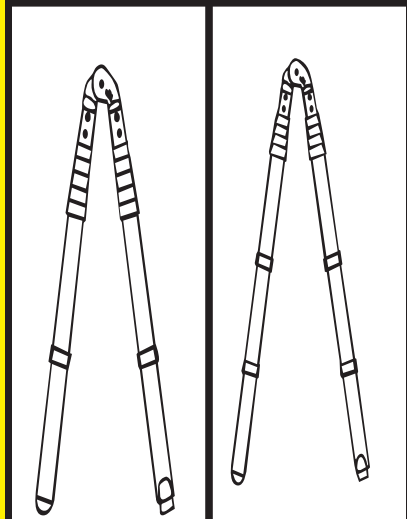
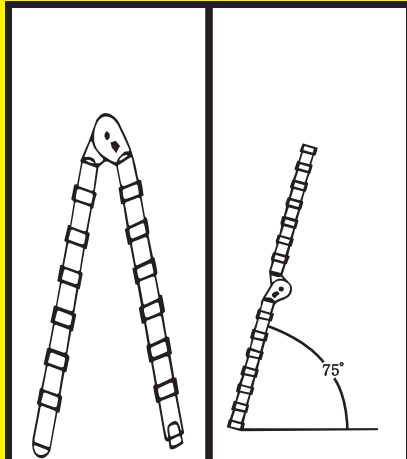

**DİKKAT**

MERDİVENİ KULLANMADAN ÖNCE  
MENTEŞELERİN KİLİTLİ OLDUĞUNDAN  
EMİN OLUN

**MENTEŞE ÇALIŞMASI**

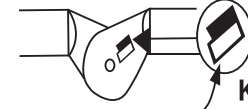

KIRMIZI KİLİT PİMİ

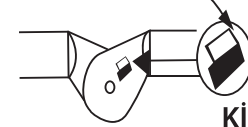

KİLİTSİZ

Menteşe kilit çubuğunu  
ortasından çekip bırakın.

**KİLİT ÇUBUĞU**

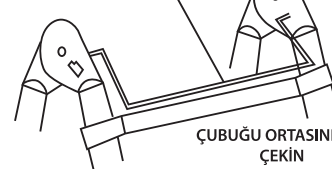

ÇUBUĞU ORTASINDAN  
ÇEKİN

Menteşeleri kilitlemek için merdiveni  
kilit konumuna getirin.  
Her iki menteşedeki kilit pimlerinin yerine  
tam oturduğundan emin olun.  
Gerekirse merdiveni hafifçe hareket ettirin.

**MENTEŞE KONUMLARI**

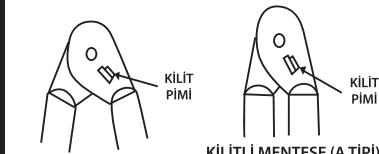

DEPOLAMA KONUSU

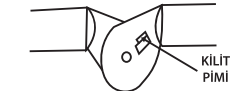

KİLİTLİ MENTEŞE (DÜZ UZAYAN)

- Kullanmadan önce tüm menteşelerin tam kilitli olduğundan emin olun.
- Menteşe kilit çubuğunu yalnızca elinizle kullanın.
- Kilit pimleri tam oturmadan merdiveni kullanmayın.
- Merdiveni taşımak veya hareket ettirmek için menteşe kilit çubuğunu kullanmayın.
- Menteşeleri temiz tutun ve gerektiğinde yağlayın.



**EN-131**